

## Art.: 3081

### Válvula de esfera para soldar / Welding ball valve

Características	Features
1. Válvula esfera con paso total.	1. Ball valve with full bore.
2. Construcción en latón s/ UNE-EN 12165.	2. Brass construction acc/ UNE-EN 12165.
3. Extremos para soldar a tubería de cobre.	3. Copper welded ends.
4. Accionamiento mediante palanca de acero.	4. Working by means of steel lever handle.
5. Temperatura de trabajo desde -20°C a 110°C.	5. Working temperature from -20°C to 110°C.
6. Presión máxima de trabajo 16 bar (PN 16).	6. Maximum working pressure 16 bar (PN 16).
7. Asientos PTFE.	7. PTFE Seats.

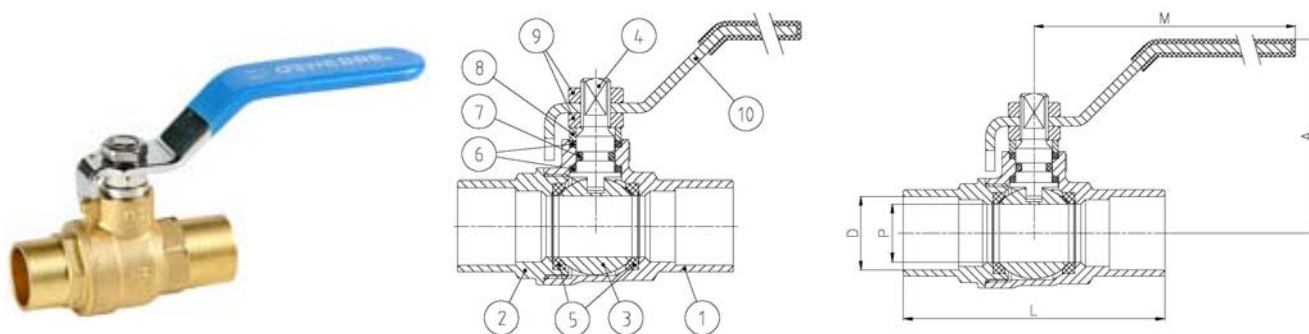

Nº	Denominación / Name	Material	Acabado Sup. / Surface Treatment
1	Cuerpo / Body	Latón / Brass (CW617N)	Granallado / Peened
2	Tapa / Cap	Latón / Brass (CW617N)	Granallado / Peened
3	Esfera / Ball	Latón / Brass (CW617N)	Cromado / Chrome plated
4	Eje / Stem	Latón / Brass (CW617N)	Cromado / Chrome plated
5	Asientos / Ball seats	PTFE	-
6	Anillo prensa/Stem packing	PTFE	-
7	Tórica / O-Ring	NBR	-
8	Anillo prensa / Stem ring	Latón / Brass	Cromado / Chrome plated
9	Tuerca / Nut	Latón / Brass	Cromado / Chrome plated
10	Maneta / Handle	Acero / Steel	Dacromet / Dacromet

Ref.	Medida / Size	Dimensiones / Dimensions (mm)				Peso / Weight (Kg)
	D	P	A	L	M	
3081 15	Ø 15	12	46	57	84	0,135
3081 18	Ø 18	15	47	64	84	0,165
3081 22	Ø 22	20	58	72	98	0,265
3081 28	Ø 28	25	61	85	98	0,380
3081 35	Ø 35	32	75	96	135	0,825
3081 42	Ø 42	40	80	115	135	1,170
3081 54	Ø 54	50	90	140	165	1,850

## DIAGRAMA PÉRDIDA DE CARGA / HEAD LOSS CHART

(Válvulas paso reducido roscadas / Threaded ends reduced bore ball valves)

Valores de Kv / Kv Values:

**Kv** = Es la cantidad de metros cúbicos por hora que pasará a través de la válvula generando una pérdida de carga de 1 bar.

**Kv** = The flow rate of water in cubic meters per hour that will generate a pressure drop of 1 bar across the valve.

Medida / Size	Ø15	Ø18	Ø22	Ø28	Ø35	Ø42	Ø54
Kv	5.5	16	30	45	70	115	210

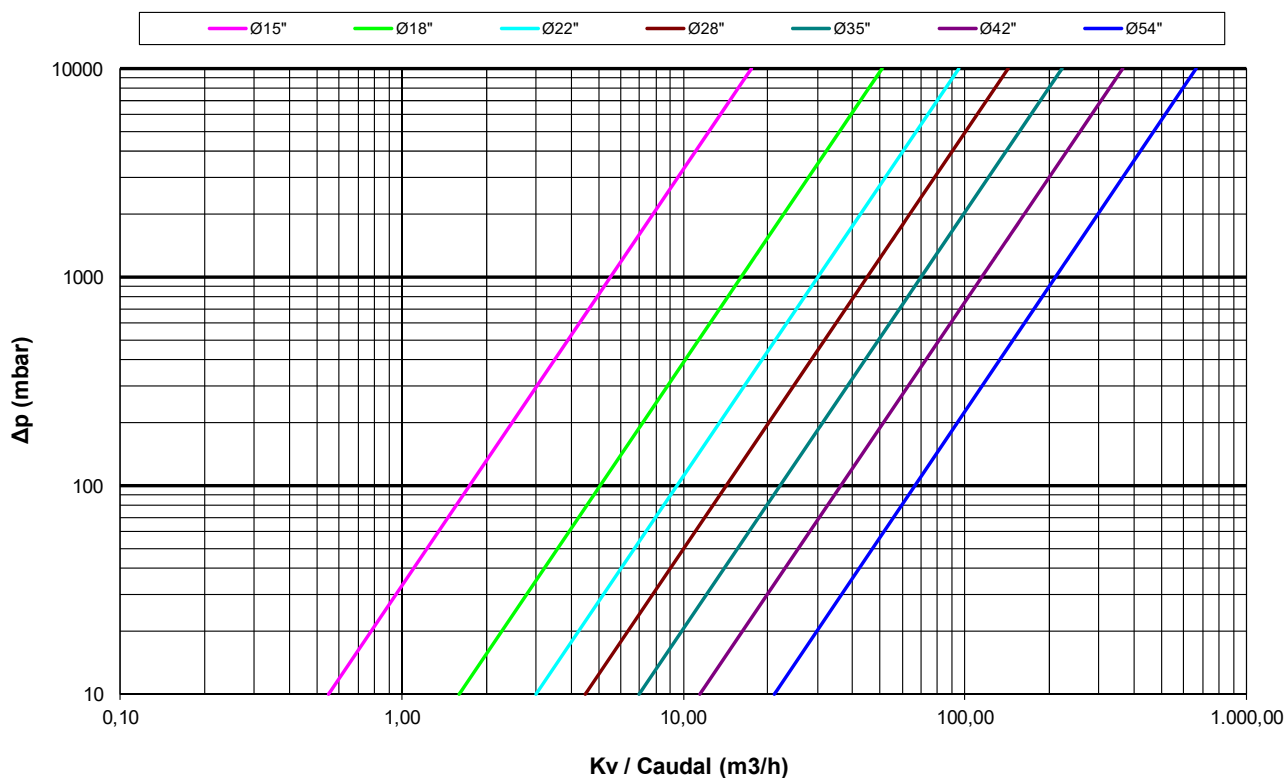

## CURVA PRESIÓN - TEMPERATURA / PRESSURE - TEMPERATURE RATING

